

I N S T R U C T I O N - M A N U A L

RF-ADMITTANCE POINT LEVEL SWITCH

FUNCTION:

The RF Admittance Point Level Switch comprises of a specially designed electronics and sensing probe using DRIVEN SHIELD COAT GUARD circuit and corresponding 3-Element Probe. The Electro-mechanical combination of the COAT GUARD technique makes the system immune to the material build-up on the probe and material bridging between the probe and the hopper wall.

The unique feature of the system is that the measured signal does not flow to the hopper wall through the probe in the backward direction but flows only through the material (actual material level) to the hopper wall.

MEASURING SYSTEM:

The sensing probe and
The Electronic Switching unit

The sensing probe consists of three sections, (1) Measuring section, (2) Coat Guard section and(3) ground section. The Coat Guard section guards the system against the transmission of RF signal through any coating on the sensing element from the measuring section to the ground. The only available path to the ground for the RF signal is through the service material in the hopper.

PRIMARY AREA OF APPLICATION

Building industry materials, cement, sand, lime, etc

Foodstuff industry, milk powder, flour, salt, foodgrains, pharmaceutical etc

Plastic industry, powder, granular etc.

Timber industry, chemical and mining etc.

TECHNICAL SPECIFICATIONS:

SWITCHING UNIT:

Housing	Cast Aluminum, weatherproof, powder coated
	Integral with the probe/suitable for back panel mounting.
Cable entry	2 nos./ 3 nos.
Ambient temperature	0 ° C to +60° C
Power consumption	1.9 VA
-	
Mains Voltage	230/110 V AC (+/-15%), 50 Hz
Output	2 sets of potential free c/o contacts rated at 5 amps, 230 V AC for non-inductive loads.
-	

Switching delay	Continuously adjustable from 0.5 to 20 sec. probe free or Probe covered.
Safety operation (FSL/FSH)	Field selected switch over for minimum or maximum switching points.
Switch status display	Green LED shows Normal and Red LED shows Alarm Conditions. Yellow LED shows Power - on condition.

COAT GUARD SENSING PROBE:

Mounting	Screwed – 1 ½” BSP (standard) Flanged (as per requirement)
Sense rod	Stainless steel
Coat Guard Shield	Stainless steel
Insulation	PTFE (standard) Other insulation on request and as per application.
Operating temperature	100 ° C max. (Inside vessel) for integral electronic model.

INSTALLATION OF RF-ADMITTANCE :

Mounting of the probe would depend upon its construction and may differ from application to application. Depending upon the application, the rigid Probe can be mounted vertically, either from the top or side. horizontally, from the hopper

The standard unit has screwed, 1-1/2” BSP mounting, which can be mounted laterally on the container wall at the desired level of the material to be controlled. The probe rod should be horizontally or pointed slightly downward.

For installing the probe vertically from the top, sufficient clearance (equal to the probe length minimum) should be available above the hopper top to facilitate to hoist the probe over the hopper top for insertion into the hopper.

Following precautions should be taken during installations -

The probe should not be bent or position distorted.

In case of flat strip probe, the edge of the strip should face the ground so that the strip surface remain perpendicular to the ground plane

The shield element of the probe (standard probe) should extend at least 50 mm into the vessel. The extended probe should be mounted in such a way that it does not extend further than necessary in the vessel. (For the boot level probe the mounting socket length should not be more than 25 mm)

During filling operation, the material should not fall directly onto the probe. Otherwise protection shield should be provided over the probe.

During installation of probe with screwed mounting, turn the hexagonal mounting bush of the probe and not the housing.

SWITCHING UNIT INSTALLATION:

The standard unit has electronics integral with the probe. For remote mounting of the Switching unit, Off the probe, the housing is suitable for back panel mounting.

For wiring and connection, refer the enclosed drawing. For remote unit only the supplied THREE TERMINAL connecting cable should be used for interconnecting probe with the Switching Unit.

The Switching unit should not be mounted at the location where the ambient temperature is not more than 60° C.

Precaution should be taken to avoid fall of Sunrays on to the Switching Unit housing. In case it is not possible to avoid, a suitable Sun protection cover should be provided over the housing.

FAIL SAFE MODE SELECTION:

Depending upon the process requirement, the minimum or maximum fail-safe mode can be selected in the **RF Admittance** .

In **RF Admittance** the Relay is in energized condition. When level changes state the relay de-energises. Thus, besides level alarm condition, the operator gets an alarm even in case of mains failure or the instrument failure. This imparts a better overall reliability of operation.

Maximum fail-safe mode means the relay de-energises when the level exceeds the desired or when mains supply fails.

Minimum fail-safe mode means the relay de-energises when the level drops below the desired level or when mains supply fails.

NOTE: The contacts shown in the connection drawing are for Fail Safe Hi condition. The contacts will reverse when the FS Link is changed to Low position.

ELECTRICAL CONNECTION TO RF-ADMITTANCE:

Please refer the connection diagram for the electrical connection. Appropriate mains voltage should be connected to the terminals of the instruments as specified. The connectors are suitable for

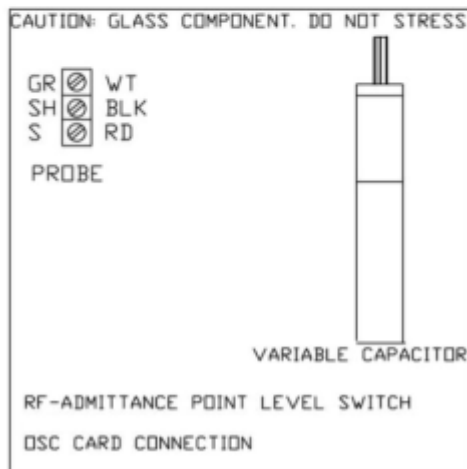
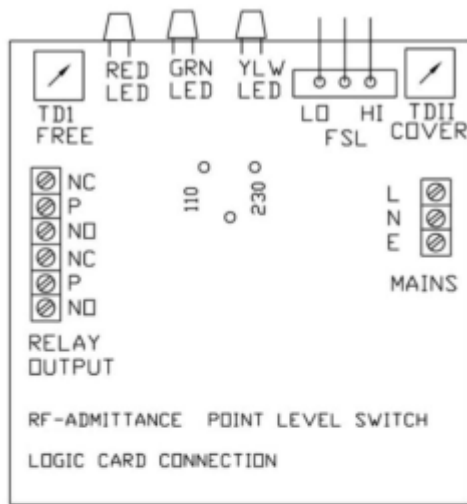

1.5 sq.mm cable cross section.

SETPOINT SWITCHING CALIBRATION

There is single adjustment in the Switching Unit and is accessible from the top. There are three LEDs on top of the Switching Unit. The Yellow LED indicates Power On condition. The Green LED indicates the relay is in the energised state. The red LED indicates the alarm condition and relay in de-energised state. The setpoint adjustment is done by multiturn variable capacitor.

(Please do not stress the capacitor, it is made of glass)

Select the Fail Same mode.

Keep the time delay pot at minimum.

Turning the capacitor clockwise will raise the level at which the relay operates and turning the capacitor counterclockwise will lower the level at which relay operates.

Please use insulated tool (small screw driver with minimum metal portion in the insulated part) for adjustment. Do not turn the capacitor beyond its limits, as it would damage the same.

Hopper should be empty or the level should be more than 300 mm below the probe.

Turn the capacitor in the full counter-clockwise position. Using the insulated tool and turn the capacitor adjustment slowly to clockwise until the relay just operates and green LED glows. Repeat the operation once or twice and note the point of switching.

Rotate the adjuster further CLOCKWISE by a half turn/ One Full turn/Two full turns, depending upon the application and the probe construction and mounting orientation. (Do not turn the adjuster counterclockwise) The instrument is set for desired switching point.

Adjust the time delay pots, as per your requirement.

MAINTENANCE

In normal conditions the RF Admittance need no maintenance.

However, if the material has built up tendency, over a period of time, probe should be cleaned whenever need occurs.

Ensure that the cable glands and the housing lid are sealed to prevent ingress of moisture.

Authorised Dealer



NK Instruments Pvt. Ltd.

B-501/504, 5th floor, Raunak Arcade, Near THC Hospital, Gokhale Road, Naupada,
Thane(W) 400602. Maharashtra INDIA Telefax Nos.: 91-22-25301330 / 31 / 32
E-Mail: sales@nkinstruments.com Web: <http://www.nkinstruments.com>
Skype: nitinkelkarskype Gtalk: nkinstruments2006

